

# Installation instructions

## Scope of delivery

1. flat tank incl. installation instructions (on flat tank)
2. compensation dome or sliding dome with cover and connections DN 100

### IMPORTANT:

Always follow the installation, setup and operating instructions provided with each unit. If you are missing installation, setup or operating instructions, please request them from your dealer or at [service@greenlife.info](mailto:service@greenlife.info).

To install a system, it is always best to follow the illustrations in the catalogues. Here you can easily see which parts are connected to each other. Then you can proceed in the following order to install the system.

Flat tank 2000 l, 3000 l, 4000 l, 5000 l  
Flat tank systems 8000 l, 10000 l

In case of ground water and on slopes, special installation instructions must be observed!

### Walkable:

If the tanks are installed in a green area which is not accessible to traffic, the earth cover over the tank body is at least 400 mm and max. 800 mm. Do not use cohesive soils: loam, clay, silt, etc.

### Car-accessible

By using the telescopic dome and the car-accessible cover (wheel load 600 kg), the tank can be installed under car-parking areas.

The ground cover in the accessible area above the tank body must be at least 600 mm and max. 800 mm. Do not use cohesive soils: loam, clay, silt, etc.

# Installation instructions

## Security

The relevant accident prevention regulations must be observed for all work (BGV C22).

For safety reasons, a second person is absolutely necessary when inspecting the tanks!

When carrying out any work on the system or parts of the system, the entire system must always be shut down and secured against unauthorised restarting!

The tank cover must always be kept closed, except when working inside the tank. Otherwise there is a high risk of accidents.

We offer an extensive range of accessories. The use of other accessories can lead to a reduction in functionality and the liability for damages resulting from this can be cancelled.

### Obligation to label

All pipes and tapping points for service water must be marked with the words "not drinking water" in writing or with pictures (DIN 1988 Part 2, Para. 3.3.2.) in order to avoid erroneous connection with the drinking water network even after years. Even with correct labelling, confusion may still occur, e.g. by children.

One possible protection against confusion by children are taps with child protection.

# Installation instructions

## Building ground

### Building ground

The following points must be clarified before installation:

- The structural suitability of the floor according to DIN 18196
- Maximum occurring groundwater levels or seepage of the subsoil
- Occurring load types, e.g. live loads

In order to determine the physical soil conditions, a soil expertise should be requested from the local building authority. The pit for the flat tank should not be made in a hollow in the ground.

## Building pit

In order to provide sufficient working space, the base of the pit must protrude at least 300 mm, better 500 mm on each side of the tank dimensions.

The distance to fixed structures must be selected so that the structure and the vessel cannot be damaged, at least installation depth equal to the distance between vessel and structure.

If necessary, the statics should be checked by a structural engineer!

The embankment must be laid out in accordance with DIN 4124. The subsoil must be horizontal and level and ensure sufficient bearing capacity.

The depth of the pit must be dimensioned so that the maximum earth cover over the tank is not exceeded. For year-round use of the system, it is necessary to install the tank and the water-bearing

system components in a frost-free area. As a rule, the frost-free depth is approx. 600 - 800 mm; exact details can be obtained from the responsible authorities.

A layer of compacted round grain gravel (grain size 8/16 according to DIN 4226 - 1, thickness approx. 150 mm) is applied as a substructure.

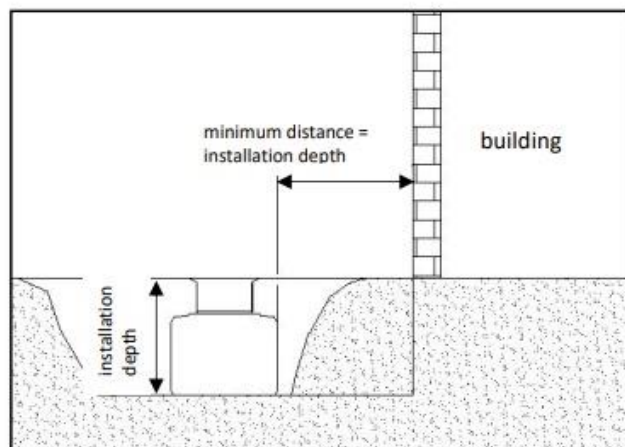

## Slope, embankment etc.

When installing the tank near a slope, mound or embankment, a statically calculated retaining wall must be erected to absorb the earth pressure. The wall must exceed the tank dimensions by at least 0.5 m in all directions and have a minimum distance of 1.2 m to the tank.

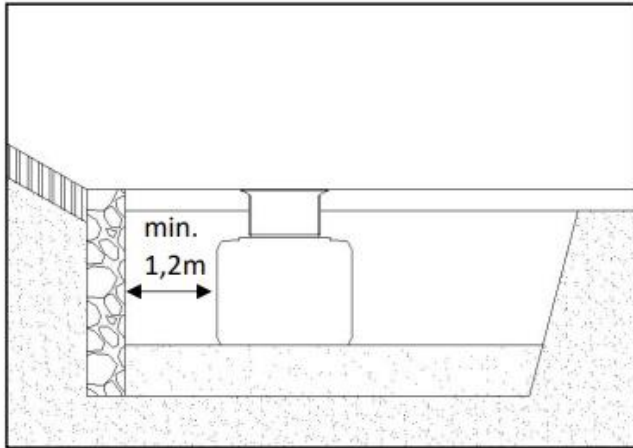

## Groundwater and cohesive soils

In the case of ground water occurring only occasionally and cohesive, water-impermeable soils (e.g. loam / clay / silt), areas at risk of flooding and waterlogging and areas with a high ground water level, at least 1.1 times the safety against floating and deformation of the empty tanks must be ensured and sufficient drainage of the ground or seepage water must be provided. A drainage pipe must end in a vertically installed shaft / pipe in which a submersible pressure pump is embedded which reliably pumps off the excess water (see figure). The pump must be checked regularly.

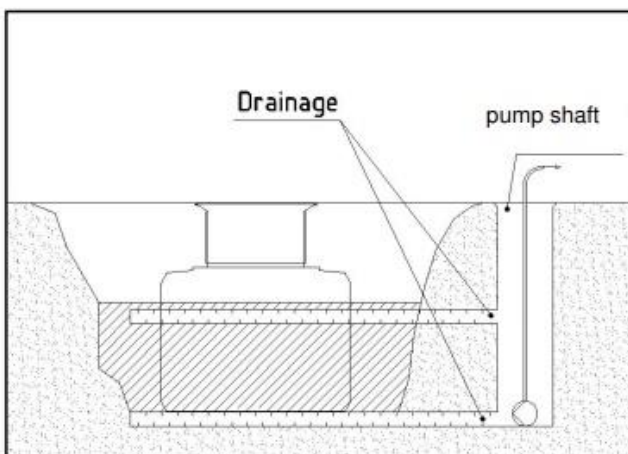

# Installation instructions

## Installation next to trafficable surfaces

If walk-on tanks are installed next to accessible surfaces, it must be ensured that the loads arising from heavy vehicles are not transferred to the tank. A minimum distance must be maintained here, which usually corresponds to the tank installation depth including additional dome and, if necessary, dome extension.

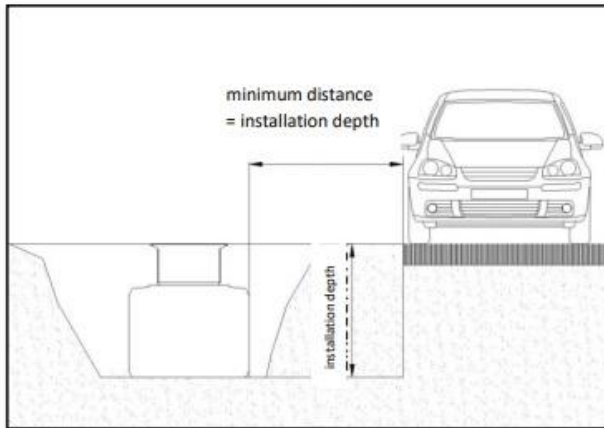

## Connection of several tanks with different water levels

The connection of two or more tanks with different water levels by means of rubber lip seals or welded-in pipe sockets. The minimum distance between the flat tanks must be 1,000 mm.

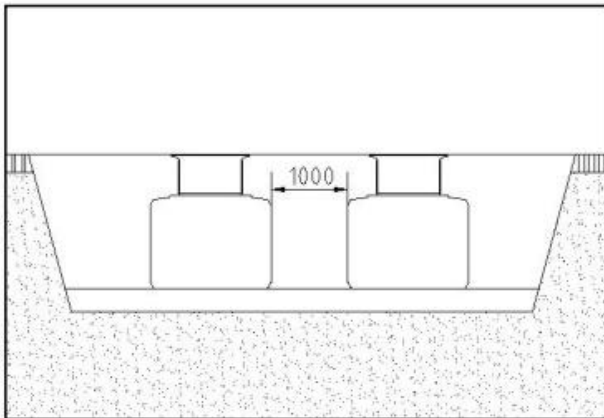

# GreenLife flat tank

## Connection of several tanks with identical water levels

To place several flat tanks next to each other, top connections must be created as air exchange between all tanks.

The bottom connection keeps the water level between the tanks equal and distributes the pressure evenly over the flat tanks.

Please note:

To avoid deformations between the tanks, the

Spaces in between carefully filled with gravel and compacted.

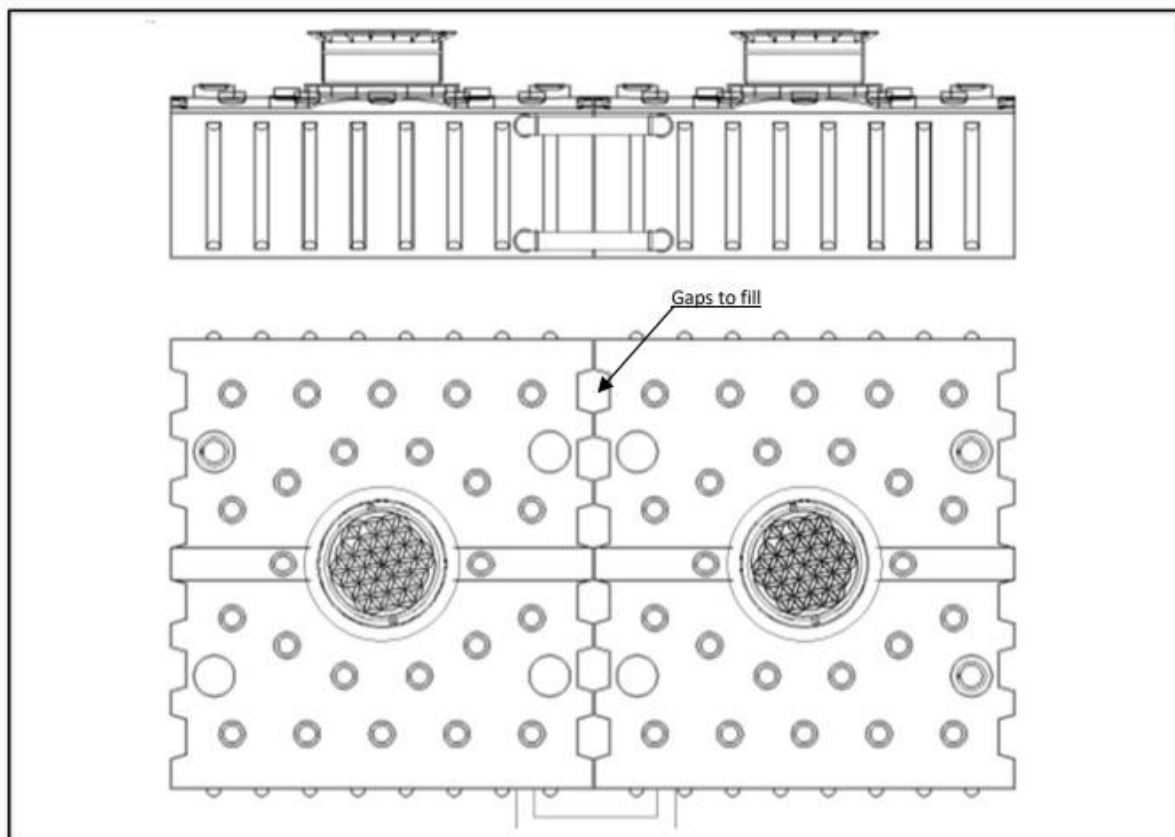

# Installation instructions

## Install connections

All supply and overflow pipes must be laid with a gradient of at least 1% (possible subsequent subsidence must be taken into account). The connection is made at the pre-drilled openings on the tank.

If the tank overflow is connected to a public sewer, it must be secured against backwater in accordance with DIN 1986 in the case of a mixed sewer using a lifting system or in the case of a connection to a pure rainwater sewer using a backwater valve.

All suction, pressure and control lines must be routed in an empty pipe which must be laid in a straight line with a gradient to the tank without any deflections.

Required bends are to be formed with max. 30° fittings. The empty pipe should be kept as short as possible.

Important: The empty conduit is to be connected to an opening above the max. water level.

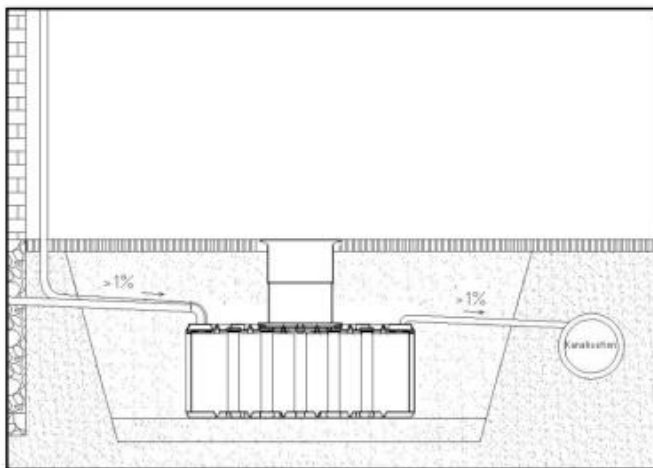

# Installation instructions

## Insertion and backfilling

The pit should be backfilled with 8/16 gravel, as this does not form any cavities and has self-compacting properties. This gravel does not store water and is therefore very seepable.

The tanks are to be brought into the prepared excavation pit shock-free with suitable equipment.

The tank environment must be seepable. The pit should be created near the connection. The flat tank should be lowered into the pit and aligned on the gravel bed with a spirit level. After the connections have been laid, the tank is aligned again using a spirit level. Then the tank is to be filled with water up to approx. 300 mm water level in the tank. Then fill the pit with round grain gravel 8/16 up to the water level and compact by hand.

Repeat the same procedure - fill up to approx. 300 mm water level, fill the pit again to the water level with round grain gravel 8/16 and compact by hand - until the tank is covered by approx. 200 mm.

Make sure that the tank is evenly embedded and compacted from all sides and that all cavities (also below the tank) are filled. Now the filling of the excavation pit is carried out. Pit excavation can be used for this purpose from 200 mm above the tank, unless the soil is cohesive, poorly water-permeable or water-impermeable. No cohesive soils above the tank may be used (e.g.: clay, loam, silt, etc.).

The surface of the filled excavation pit should be such that surface water cannot collect here to seep away.

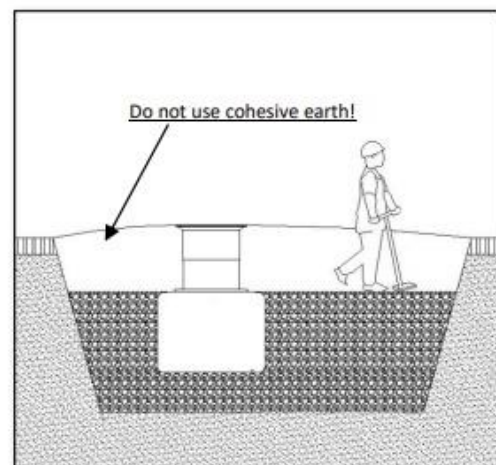
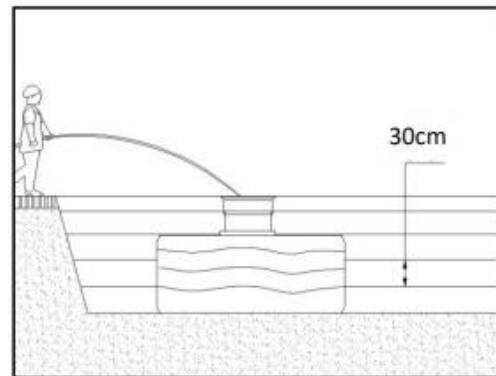

## sliding dome / telescopic dome

Important: To prevent the transfer of loads to the tank, the dome is filled in layers with round grain gravel (grain size 4/8) and evenly compacted. Damage to the tank or dome must be avoided. The cover is then placed on top and sealed childproof. Tighten the screws on the plastic cover so that they cannot be opened by a child.

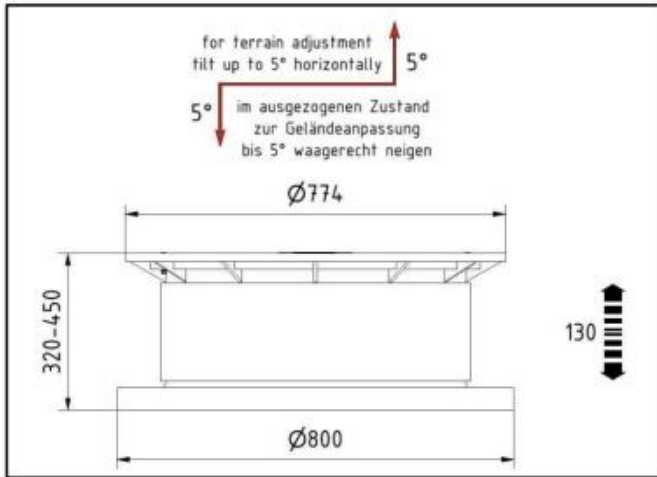

## Set car passability

There must be a minimum distance of 100 mm between the sliding dome (1) and the adapter (2), as the load distribution may only be on the substructure of the sliding dome environment and not on the flat tank. The ground cover in the area of traffic above the tank shoulder must be at least 600 mm and max. 800 mm.

For this purpose, the area around the sliding dome is filled with gravel of grain size 4/8 in layers of 40 - 50 mm and carefully compacted by hand using a wooden tool. (4 kg drop weight, drop height 100 - 200 mm, 150 x 150 mm compaction area). Then the sliding dome is pressed down to gravel level and the cover frame is compacted into the gravel using a wooden or rubber tool. Compaction is done up to the shoulder height of the tank, by hand. Compaction must be carried out in accordance with the requirements of DIN EN 13285.

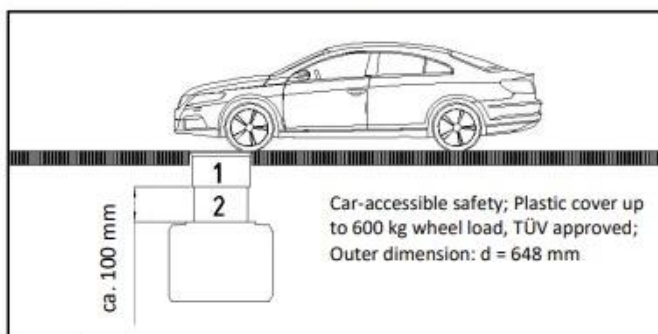

# **Installation instructions**

## **Inspection and maintenance**

The entire system must be checked regularly for leaks, cleanliness and stability. Maintenance of the entire system should be carried out at intervals of approx. 5 years. During this time, all system components must be cleaned and checked for proper function. Proceed as follows for maintenance:

Empty the tank completely, remove solid residues with a soft spatula, clean surfaces and built-in parts with water, remove dirt from the tank completely, check all built-in parts for their tight fit.

## **Installation as drainless collecting pit for domestic sewage**

The GreenLife rainwater tanks can also be used as a drainless collection pit for domestic wastewater. The installation is carried out according to the above mentioned installation instructions. The supply and vent pipes are connected to the pre-drilled openings. The remaining openings must be closed with KG-pipe stoppers DN 110.

Questions?

GEP Water  
Tel +31(0)183-610520  
info@gepwater.com