

IRM®-3S/ IRM®-5S WATERMANAGER

Rainwater changeover system with pressure immersion pump



rethinking water



PRODUCT DESCRIPTION

The IRM®-3S & 5S Water Manager is a complete rainwater system in combination with a pressure immersion pump in the rainwater tank for the use of rainwater in single-family homes. The break tank for drinking water supply is in accordance with EN1717 type AB, content 7 liters The Water Manager is supplied with a pressure immersion pump (combi-press 5-30 or combipers 5-60) with 2 connections on the suction side. The pump is supplied with a floating suction hose for mounting on the suction side. The other suction side is used to connect the drinking water supply from the IRM®-S Water Manager.

The motor-controlled ball valve provides the supply of drinking water to the pressure submersible pump. In the absence of rainwater, the system automatically switches to drinking water by means of the float with a 20 meter cable length. The control also provides for automatic drinking water refreshment of the break tank with long-term use of rainwater. The Watermanager is provided with a sound-proof EPP housing. The IRM®-3S & 5S Water Manager is suitable for wall mounting. Device is KIWA, Belgaqua and DVGW certified.

SCOPE

The system can be used for the use of filtered rainwater for flushing toilets, connecting a washing machine and an outdoor tap. Also suitable for continuous consumption such as sprinkling. Appliance is suitable for wall mounting.

TECHNICAL DATA

Height A in mm:	596
Width B in mm:	662
Depth C in mm:	365
Drinking water connection D:	3/4"
Suction pipe E:	1"
Pressure line F:	1"
Emergency overflow G in mm:	Ø75
Volume breaktank in liters:	7

TECHNICAL SPECIFICATIONS 5-30

Voltage in V:	230	230
Power in Watt:	550	750
Max. debiet in liter/min:	65	85
Max. opvoerHeight in m:	34	58
Leeggewicht in kg:	21	21
Aantal waaiers	3	5
Condensator in µF:	20	25

MATERIAL

NAAM	Material
Soundproof hood:	EPP
Breaktank:	HDPE
Pump housing:	RVS (304)
Rotor:	RVS (410)
Leiwiel / air separator:	PPO (noryl)
Electro cable pump:	3 aderig 1,00 mm ² H07Rn-F

Double shaft seal silicon carbonate and aluminum oxide / ceramic in oil-filled chamber, suction hose bacterial-inhibiting thermoplastic. Suction basket and hose clamps stainless steel.

TECHNICAL DRAWINGS

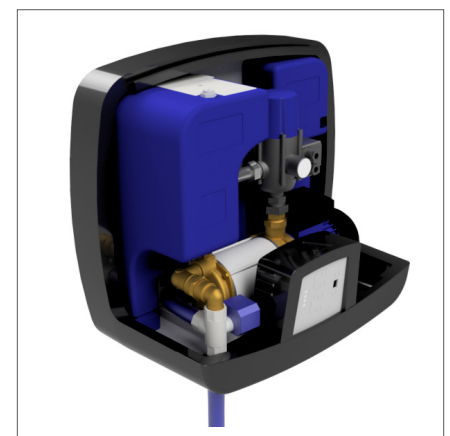
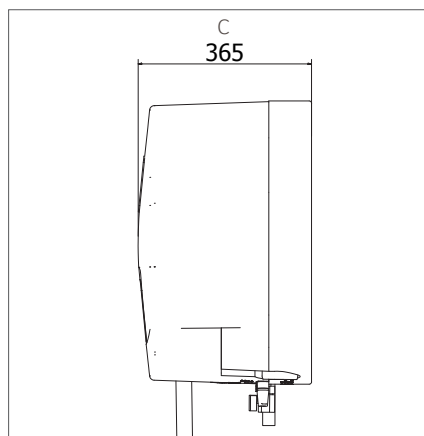
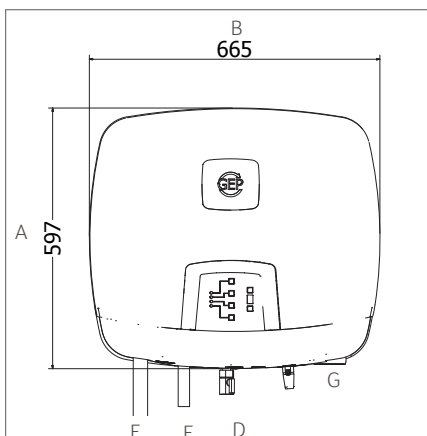

PUMP CHARACTERISTIC

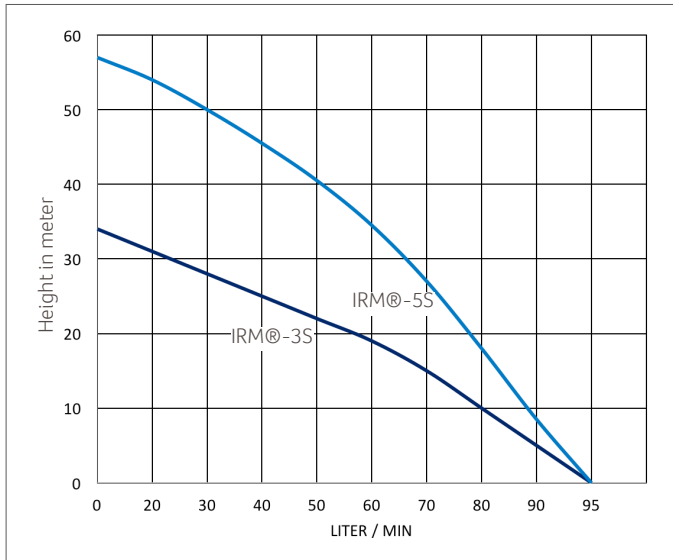

CONNECTION DIAGRAM

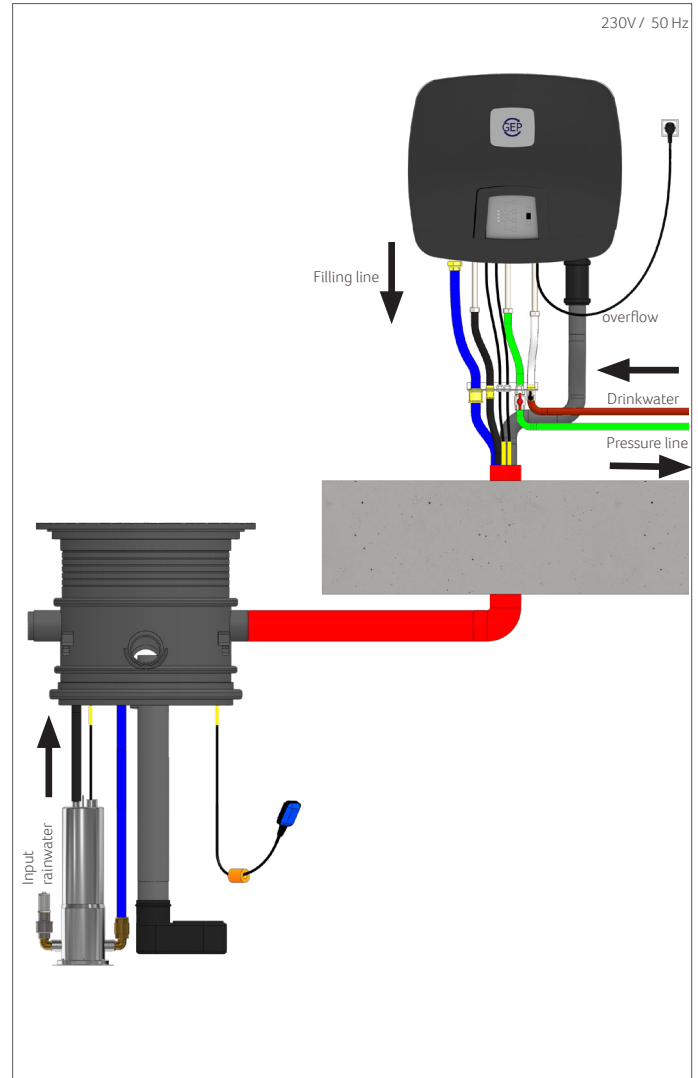

OPTIONS

Water lock IRM@ 3S / 5S

If there is no Emergency overflow connection present, the device can be extended with a water seal, which closes the drinking water supply with a leaky drinking water valve.

Automatic time-controlled filter cleaner 1/2 "

Set consisting of: adjustable automatic timer, solenoid valve 1/2 "including 1,5m cable and plug. Digital display.

Submersible pump kit

Stainless steel wire and mounting parts to be able to attach the submersible pump to the top of the rainwaterput.

SCOPE OF DELIVERY

Water manager IRM@-3S / IRM@-5S is supplied with: Combipress submersible pump 5-30 / 5-60, floating suction hose with 60 cm hose, flexible stainless steel hoses for connection of drinking water, suction and Druckleitung including stop valves, float with 20 meters of cable and cable clamp for tank mounting, mains cable of 2 meters, wall bracket with rubber resonance strip, fastening Material and installation instructions.

ORDERING INFORMATION

Art nr	NAME	PG
402114	IRM@-3S Watermanager	1
402115	IRM@-5S Watermanager	1
402138	Water lock IRM@ 3/5	1
401155	Automatic time-controlled filter cleaner 1/2 "	2
402253	Revision set	1

