

TRIDENT CONE FILTER

Trident 150 cone filter with skimmer overflow and support assembly

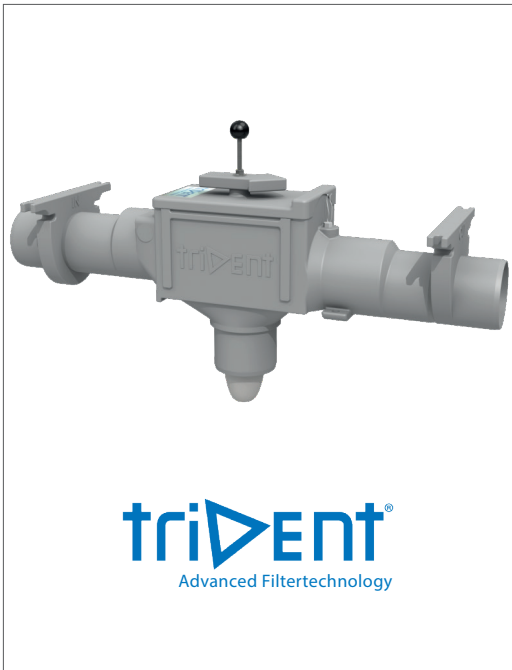

PRODUCT DESCRIPTION

Trident filters are a highly efficient dynamic rainwater filter, ensuring that a maximum volume of water passes through the filter and into the tank. The filter acts as the first step in the rainwater treatment process and has the capability to reduce the overall lifetime cost of the entire rainwater harvesting system.

With a range of pre-tank filters and tank filters with skimmers, Trident filters are flexible to suit in almost any tank; improving tank life, reducing maintenance and capable of handling high volume harvesting needs.

- +90% Efficiency 700µm
- Rapid separation of waste and clean water
- Dirt resistant and large effective filter grid
- Automatic cleaning reduces maintenance required
- Ideal for rainwater harvesting

APPLICATION AREA

The Trident cone filter is supposed to be attached to the cover plate in a rain water borehole. The Trident cone filter is suitable for filtering rain water from roofs of homes or buildings with a roof surface up to 150 m² (based on 300 litres/sec/ha). Has a connecting diameter of Ø 110 and is provided with mounting brackets. The Trident cone filter must be built into a rain borehole and is, as such, not resistant to soil pressure. The filter box is detachable for the purpose of inspecting the filter plate.

TECHNICAL DATA

Height in mm:	335
Width in mm:	231
Length in mm:	880
Height difference of the supply in mm:	20
Connection waste water in/out in mm:	Ø110
Clean water out in mm:	Ø110
Weight in kg:	ca. 3,2
Opening with cover in cm:	27 x 16
Material housing:	PE
Material filter grid:	RVS
Connection filter cleaner (optional):	1/2"

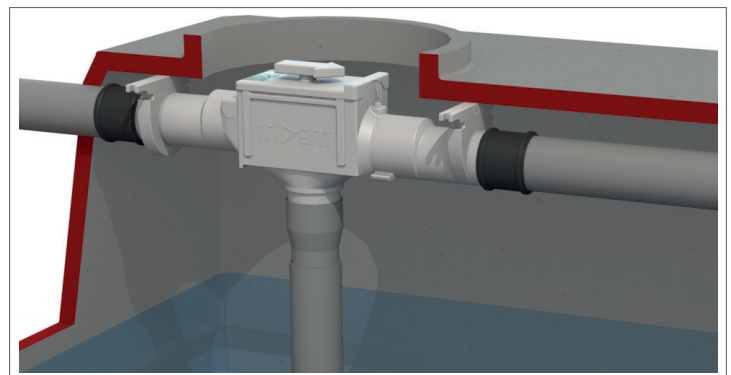

TECHNICAL DRAWING

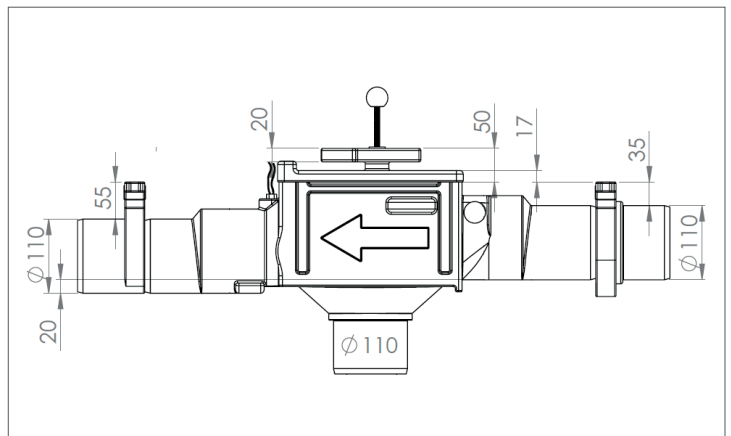
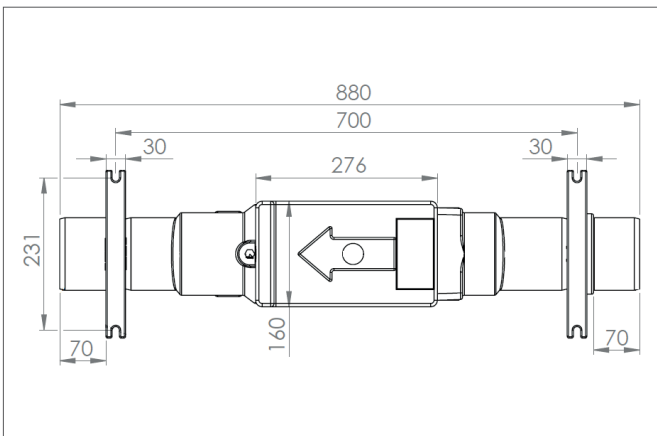

OPTIONS

Nozzle set for Trident 150, 325 and 450 tank filter
Allows easy and automatic cleaning of the filter. The nozzle cleans the filter surface by means of water pressure via a special powerful brass cone nozzle (see 1).

Automatic time-controlled filter cleaner 1/2 ''
Time-controlled filter cleaner makes automatic filter cleaning possible. The nozzle sprays the filter surface at freely adjustable times clean.

Fine filter bag
The fine filter bag can be placed under the Trident filter plate. The fine filter bag filters very finely to a mesh size of 150 µm. This fine filter can be used in places where high demands are placed on the water quality. (see 2)

Backflow alarm for Trident filters
The filter can be equipped with an alarm sensor that flows back from the overflow signals. This alarm sensor can be connected on an IRM rainwater system that switches to drinking water as an alarm signal comes from the sensor. This will contaminate sanitary appliances, pump and pipes (see 3).

Rat valve stainless steel
Stainless steel rat valve can be used in the Trident 150 and 325 tank filter. Prevents ingress of vermin from the overflow to sewer or surface water.

Twist mounting bracket
The filter can be supplied with a bracket for mounting a floating suction.

TECHNICAL OVERVIEW

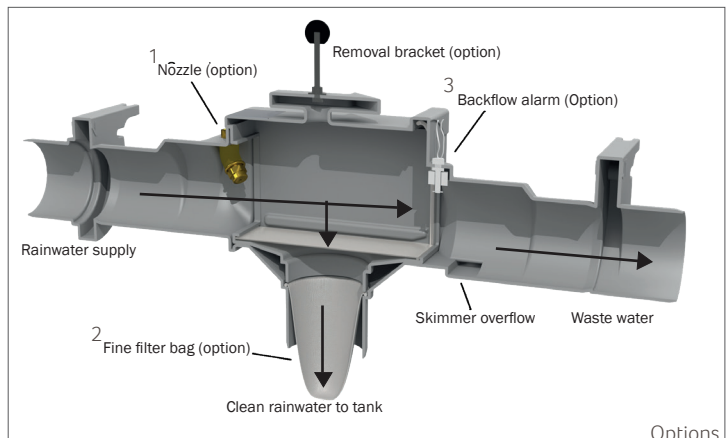
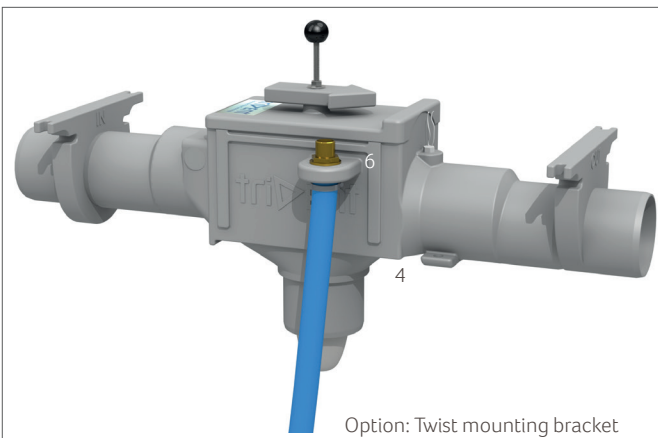

DELIVERY

Product consist of: filter housing, filterbox, Trident filter grill with removal bracket and installation instructions.

ORDER DETAILS

Art nr	NAME	PG
401127	Trident 150 cone filter with skimmer overflow	2
401131	Trident 150 cone filter with Twist mounting bracket	2
401151	Nozzle set for Trident 150, 325 and 450 tank filter	2
401155	Automatic time-controlled filter cleaner 1/2''	2
401157	Fine filter bag	2
401158	Backflow alarm for Trident filters	2
401369	Removal bracket for filterbox	2
401162	Trident 150 click connection set 110 mm	2
401165	Check valve for Trident 150 tank filter	2

